

HIGHBIKEREAR CYCLE CARRIER

SUMMIT

High lift rear carrier
Rigid & lightweight
Fits most vehicles including vans
Carries up to 3 standard cycles

Nylon straps
Foam pads prevent damage to your vehicle
Folds away for easy storage

www.summitravel.com 0844 721010

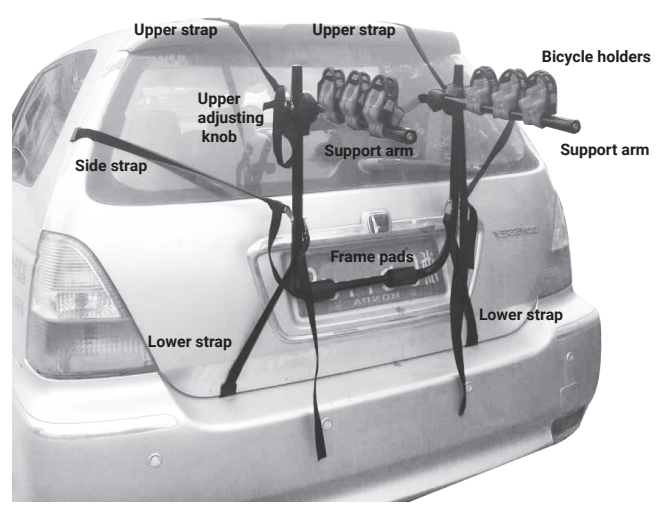

Fitting & operating instructions

Notice

This product should be properly installed before use. Incorrect installation might lead to damages to the product, bicycle, or the vehicle it is being fitted to. Following these installation instructions will ensure that the bike and carrier remain secure for general driving and in the event of an accident. This product is not suitable for vehicles fitted with a rear mounted wheel. Before installation, please check that the contents include the following:-

Checklist

Before installation, please ensure that the contents include the following:

- 1x Cycle carrier frame including pre attached 6 cycle frame clamps
- 40x6mm bolts x2
- M6 nylock lock nuts x2
- 13mm M6 washers x2
- Steel anchor loops x4
- Plastic strap buckles x4
- 1190mm straps with plastic coated fitting hook x2
- 930mm straps with plastic coated fitting hook x4

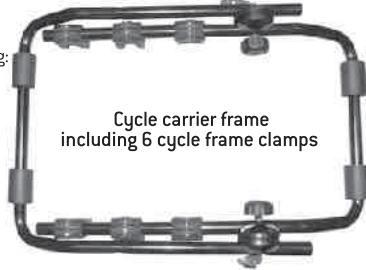

Cycle carrier frame including 6 cycle frame clamps

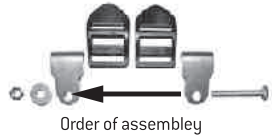

Order of assembly

Lower strap anchor point components

2x 40x6mm bolts	
2x M6 nylock lock nuts	
2x 13mm M6 washers	
4x steel anchor loops	
4x plastic strap buckles	



Straps with plastic coated hooks

- 2x 1190mm straps with plastic coated fitting hook.
- 4x 930mm straps with plastic coated fitting hook.

1 Preparation

- Before installation of the carrier, clean the vehicle surfaces that will be in contact with the carrier or straps, as well as the hooks.

2 Installation – adjust carrier to fit the vehicle

- Remove the bicycle carrier and contents out of the cartons.
- Place the cycle carrier frame the correct way for installation as shown in the pictures to the right in accordance to the types of vehicle.
- Unscrew the locking mechanisms located on the cycle carrier frame to adjust the carrier to the correct position.

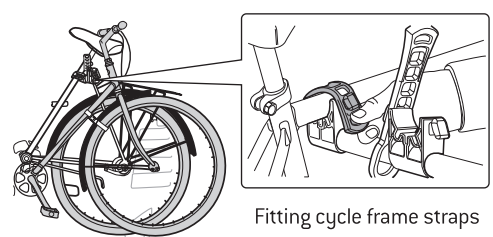

3 How to Use and Install the Bike Carrier

- Always use the straps to fix the bicycle on the carriers.
- Do not put the tyre near the vehicles exhaust pipe exit, to prevent damage to the bicycle tyre.
- The weight of the bicycle or bicycles may cause the straps to loosen, so prior to taking the vehicle onto the road please re-check all fitting straps and tension if necessary.
- It is necessary to check all the straps are fastened periodically: it is important that you check the carrier after driving over a rough or uneven surfaces. If you notice that the carrier or bicycle(s) have moved, it will be necessary to stop the vehicle in a safe position and check the carrier.

Will fit most Estate vehicles not shown



4 Fitting the lower strap anchor points

- Select one of the 40x5mm bolts, then simply pass through one of the steel anchor loops (see illustration on the front of this document) next push bolt with steel anchor loop through the pre drilled hole in one of the lower frame tubes.
- Next place another steel anchor loop onto the end of the protruding bolt followed by one of the steel washers now finger tighten on an M5 nylock nut.
- Using two 10mm spanners (not supplied) tighten, do not overtighten allow a little movement for adjustment.



5 Adjustment

- Turn/unscrew the locking mechanisms knobs located on the cycle carrier frame to adjust the carrier so that there is a minimum of a 20-degree angle facing upwards (As shown). Then tighten the locking mechanisms until secure.



Unscrewing one of the locking mechanisms

6 Attachments of Straps

- Once the carrier frame is in the correct position, Take the two 1190 straps with plastic coated fitting hooks and four 930mm straps with plastic coated fitting hooks that are to be placed in each of the fasteners. To fasten, adjust the straps to the correct length and at the same time push the safety button to fasten the belt. Make sure that the belts are securely fastened.



Feeding the top straps through the spring locking clasp

7 Top Straps Fastening (930mm)

- Fix the two upper strap hooks (in a secure place) on the rear of the vehicle or seals around the rear vehicle boot.
- Adjust the straps in accordance to the correct position. Make sure that these are secure and are as central as possible to prevent loosening.



Typical top fitting position

8 Bottom Straps Fastening (1190mm)

- Fix the two bottom strap hooks (in a secure place) on the rear of the vehicle.
- Make sure that the belt will not collide with anything that might cause it to break. Make sure that these are secure and are as central as possible to prevent loosening.



Typical bottom fitting position

9 Side Straps Fastening (930mm)

- Fix the two side strap hooks (in a secure place) on the rear sides of the vehicle. One should be securely fastened to the left hand side of the vehicle and the other to the right. (Make sure that the bottom straps are fastened tightly followed by checking the top straps before fastening the side straps, retighten where required).

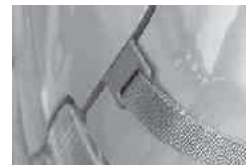

Typical side fitting position

10 Fastening the Bicycle(s) to the holders

- Place the bicycle on the carrier in to the bicycle holders. Make sure that the peddles or handlebars will not scratch the rear of the vehicle. The tyre must be put at least 30cm away from the exhaust pipe outlet.
- Use the other straps to fix the bicycle to the holders (it is recommended that all parts of the bicycle are securely fastened).
- Refasten the straps and tighten the adjusting knobs (they may have come loose after the weight of the bicycle(s) has been placed on the carrier).
- It is necessary to check all the straps are fastened periodically: it is important that you check the carrier after driving over a rough or uneven surfaces. If you notice that the carrier or bicycle(s) have moved, it is necessary to stop the car in a suitable position and check the carrier.

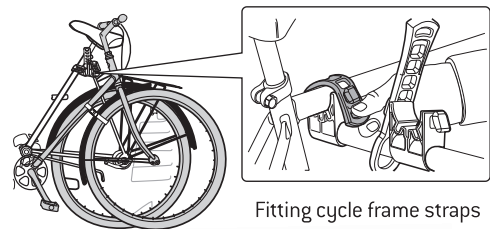

Fitting cycle frame straps



Caution

Please note that when fitting this carrier to some vehicles it may obstruct visibility of the number plate. In this instance we would suggest fitting a number plate mounting board.